

# SLIDE<sup>v.1.0</sup>

Play Video



[en.nooraneh.com/installation-video/](http://en.nooraneh.com/installation-video/)

Installation Manual for Slide Series Luminaires



WEST PADIDAR ST, ALEF SQUARE,  
ZAFARANIEH, TEHRAN, IRAN.  
TEL & FAX: (+98) 02179924  
EMAIL: [sales@nooraneh.com](mailto:sales@nooraneh.com)



Factory: Jey Industrial Area, Isfahan



---

**Dear Customer, thank you for your purchase and trust. Please read and review the instruction .manual before opening the product packaging**

---

### **Features of Slide**

- ① Uses high-efficiency COB LED modules
- ① Body made of extruded aluminum with electrostatic powder coating
- ① COB LED modules with a lifespan exceeding 50,000 hours
- ① Electronic driver with efficiency over %95 and a power factor of > 0.9
- ① Available with multiple beam angles (20°, 30°, and 50°)

## Warnings



Installation and use must be performed only by a qualified technician.



Power must be disconnected before installation. Follow international and safety standards.



All products come with a -5year warranty covering the quality of the components and the quality level of the light output.



The manufacturer is not responsible for damage caused by improper installation or usage.



Only the manufacturer, their representatives, or certified personnel may replace or modify the light source.



A separate electrical panel with full protection systems must be used for power supply,



Avoid compressing or striking the product during transport and storage



During construction work like welding, lights must be off or stabilized to avoid



Do not touch the LED module directly or strike it.



The fixture must only be powered through its provided driver; using a different driver or direct power connection may cause damage.



No drilling, cutting, or modification of the lighting electrical system is required. Avoid impact or pressure on the diffuser and luminaire body.



The luminaire operates safely at very low voltage and does not require grounding of the power driver.



For any further questions or information, please contact NOORANEH's after-sales service.

**Packaging:**

The carton opens from the front. The product packaging includes the item itself, the installation accessories, and the user manual.

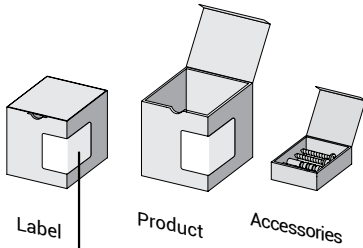
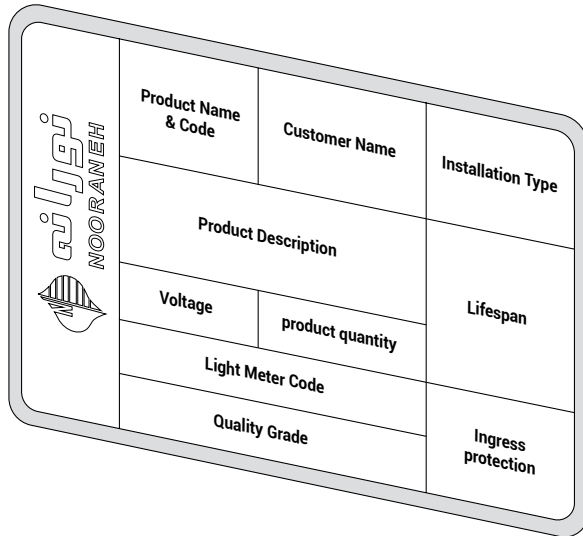
	Product Name & Code	Customer Name	Installation Type
	Product Description		Lifespan
	Voltage	product quantity	
	Light Meter Code		Ingress protection
	Quality Grade		

**Specification Label**

All necessary information for complete product identification is provided on the label. The label is affixed to the carton body.

Dream Installation Guide

# Recessed

PMi

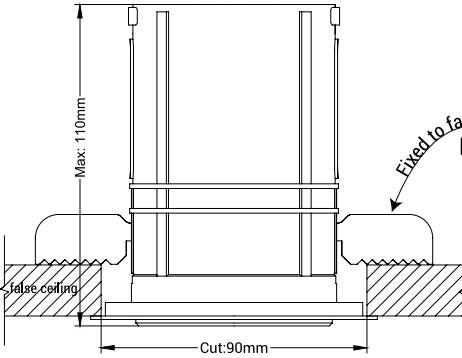
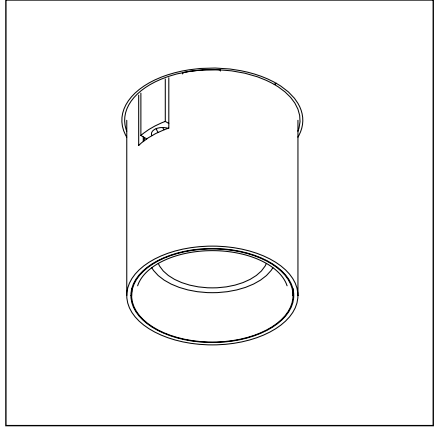

Fixed to false ceiling **1**

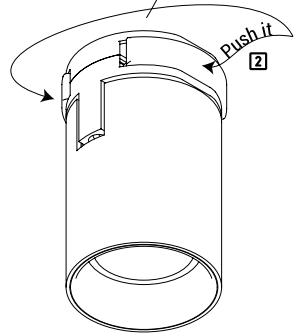
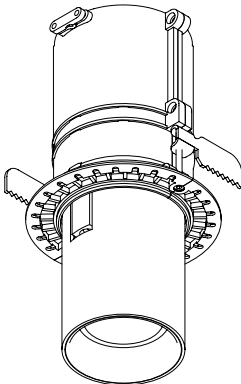
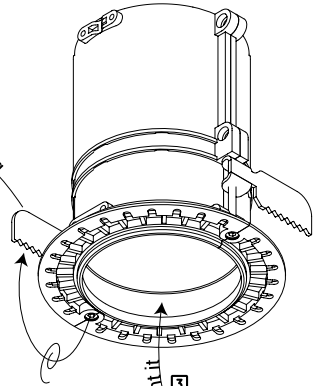

0 2 1 - 7 9 9 2 4

[sales@nooraneh.com](mailto:sales@nooraneh.com)

[nooraneh\\_lighting](#)

[www.nooraneh.com](http://www.nooraneh.com)

